



GROUTING EQUIPMENT DIVISION

WINCHESTER, VA



PD1011E

HIGH SHEAR
COLLOIDAL MIXER

Specifications

- ▶ Electric: 480V - 3 Phase
- ▶ Progressive Cavity Pump (38 GPM, 240 Max PSI)
- ▶ 74 Gallon Mix Tank
- ▶ 198 Gallon Holding Tank
- ▶ Equipped with Colcrete Colloidal mill
- ▶ Dimensions: 80" x 89" x 84"
- ▶ Weight: 5,500 lbs.

The PD1011E is our electric version of the PD1011H workhorse unit. This unit is powered by 2 separate electric motors to turn the agitator and Colcrete high shear mill. This eco-friendly model is great for deep foundation projects and underground operations alike due to the zero emission output.

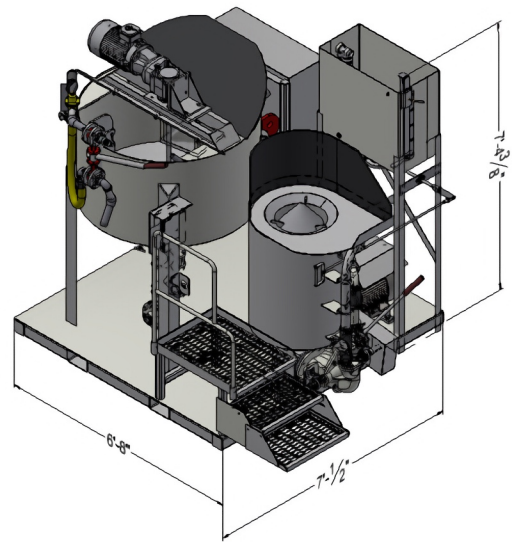

HIGH STRENGTHS WITH HIGH SHEAR MIXING

High shear colloidal mixing allows for lower water/cement ratios compared to conventional mixing, producing the strongest grouts possible. With a discar speed of 2,100 rpm, this results in a mix that can be pumped and remain stable without separation to permeate voids uniformly. This method of mixing is especially effective at dispersing tough materials like bentonite and other foundational mixes.



We offer in-stock units for quick sales and rentals. Additionally, we can customize this model to meet your specific requirements.

FOR MORE INFORMATION:

 866-459-5309

 SALESVA@PENNDRILL.COM

 PENNDRILL.COM