



## GROUTING EQUIPMENT DIVISION

WINCHESTER, VA



# PD15H

SUPER SACK  
CEMENT SILO

### Specifications

- ▶ Hydraulically Driven
- ▶ 6,000 lbs. Capacity
- ▶ 8 ft Screw Conveyor
- ▶ Weight Batching System with pendant equipped
- ▶ Dimensions: 156" x 94" x 120"
- ▶ Weight: 2,250 lbs.

The PD15H Super Sack Silo is capable of directly marrying up to our PD1011H's power supply to maximize grout production and minimize jobsite footprint. This auger fed silo is smaller and easier to fit onto a jobsite without losing grout output capabilities. Equipped with weight batching and pendant controls for easy one-man operation.

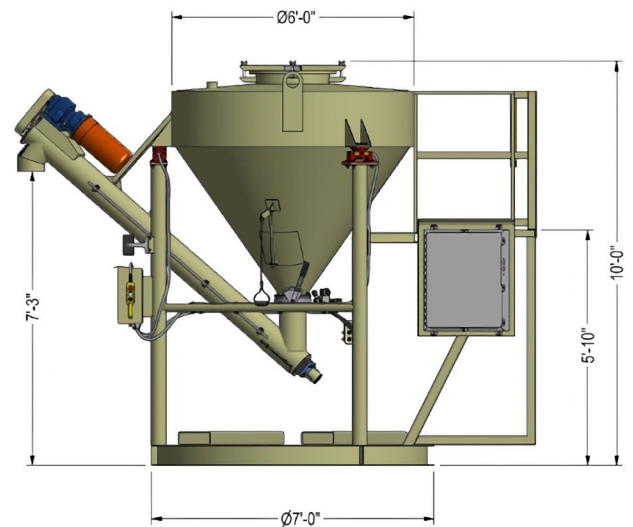

### EFFICIENT BULK MATERIAL DELIVERY SILO

Our PD15 is a super sack, 6,000 lb. silo that delivers cement, bentonite, or other materials to the mixing tank with the push of a button. This eliminates the need for bags, reduces cleanup, and increases accuracy by using bulk materials. It also saves time and money by lowering product and labor costs.



We offer in-stock units for quick sales and rentals. Additionally, we can customize this model to meet your specific requirements.

**FOR MORE INFORMATION:**

 866-459-5309

 SALESVA@PENNDRILL.COM

 PENNDRILL.COM