



GROUTING EQUIPMENT DIVISION

WINCHESTER, VA



PD1011H Training

PD411H

HIGH SHEAR
COLLOIDAL MIXER

Specifications

- ▶ Diesel to Hydraulic Drive
- ▶ Progressive Cavity Pump (38 GPM, 240 Max PSI)
- ▶ 40 Gallon Mix Tank
- ▶ 65 Gallon Holding Tank
- ▶ Equipped with Colcrete Colloidal mill
- ▶ Dimensions: 96" x 77" x 77"
- ▶ Weight: 5,700 lbs.

Our PD411H is a perfect option for a small jobsite. This unit mirrors the PD1011H capabilities with smaller tanks and frame size to fit on any jobsite. The PD411H still maintains the Colcrete high shear colloidal mill to be able to handle almost any material for mixing. This unit is especially great for Helical Piles!

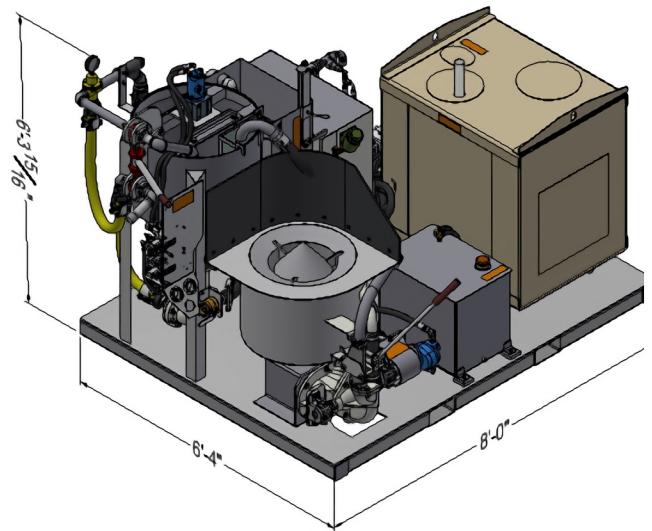

HIGH STRENGTHS WITH HIGH SHEAR MIXING

High shear colloidal mixing allows for lower water/cement ratios compared to conventional mixing, producing the strongest grouts possible. With a discar speed of 2,100 rpm, this results in a mix that can be pumped and remain stable without separation to permeate voids uniformly. This method of mixing is especially effective at dispersing tough materials like bentonite and other foundational mixes.



We offer in-stock units for quick sales and rentals. Additionally, we can customize this model to meet your specific requirements.

FOR MORE INFORMATION:

866-459-5309

SALESVA@PENNDRILL.COM

PENNDRILL.COM