



**GROUTING EQUIPMENT DIVISION
WINCHESTER, VA**



**PDGP20
DOUBLE ACTION
PISTON PUMP**

Specifications

- ▶ Hydraulic Drive
- ▶ 20 GPM Max Output
- ▶ Available in 500 PSI or 1000 PSI option
- ▶ Variable Flow Control

RELIABLE, VERSATILE GROUT PUMPS FOR ANY JOB

Our double-action piston grout pumps are engineered for reliability and easy maintenance, ensuring your job site stays on schedule. With variable flow control, these pumps seamlessly handle any cementitious or bentonite-based grouting materials, offering the versatility you need for a wide range of applications. Built tough for demanding environments, our pumps provide the consistent performance and durability you can count on, while minimizing downtime and maintenance hassles. Choose between 500 or 1000 PSI options to meet the specific demands of your project with precision and efficiency.

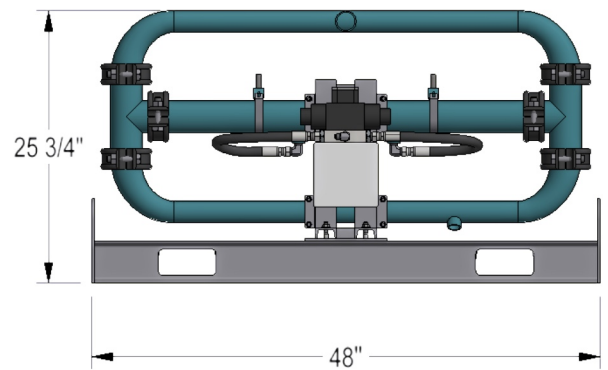
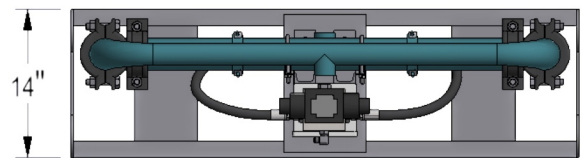

These units pair exceptionally well with our PD1011H and PD411H to increase their max pressure and overall versatility.

FOR MORE INFORMATION:

 **866-459-5309**

 **SALESVA@PENNDRILL.COM**

 **PENNDRILL.COM**